

ADAMS



Rotary Tight Shut-Off Valves
MAK

ADAMS





Product development and manufacturing strictly follow the **company's philosophy** to serve our customer with

- **uncompromising quality**
- **robust, well-proven designs**
- **innovative engineering**
- **long-term corporate commitment to quality**

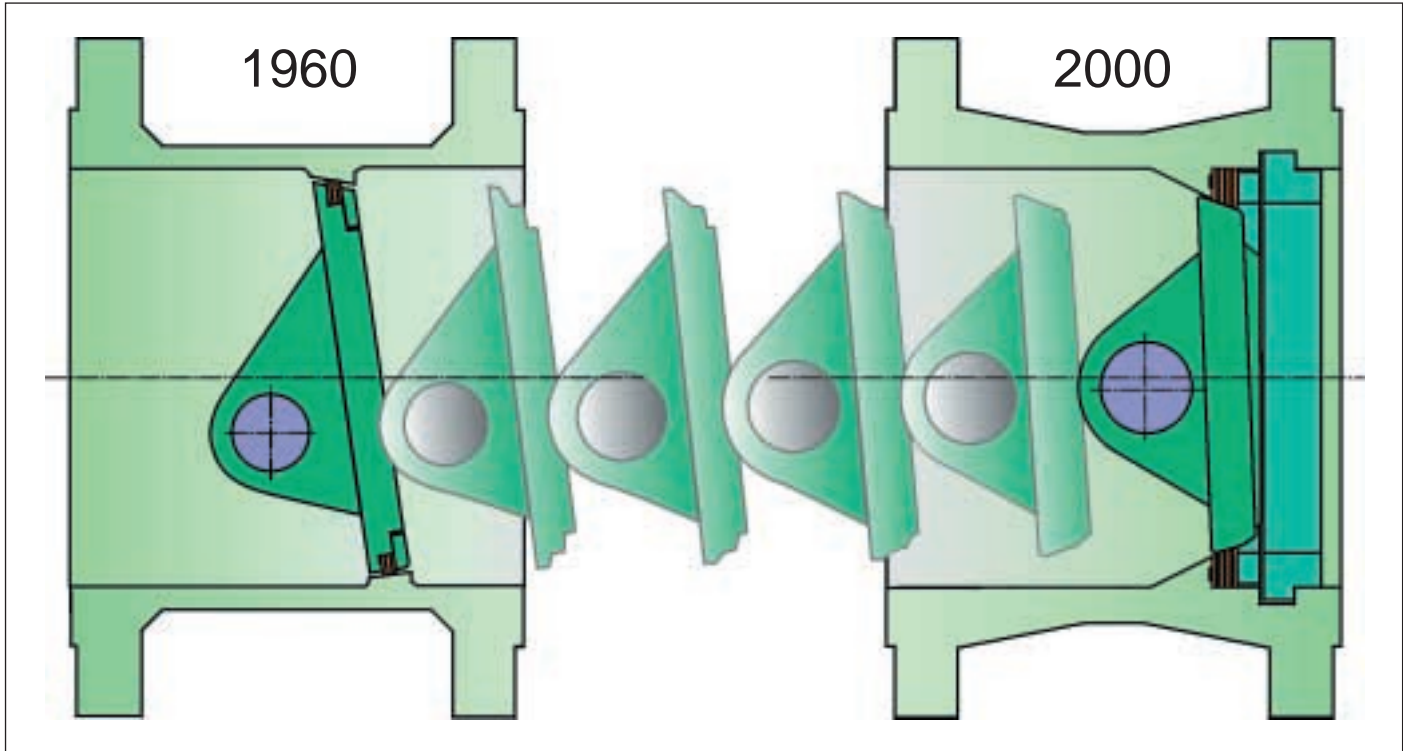

ADAMS created the Inclined Conical Sealing System and remains the leader in Rotary Tight Shut-Off Valve Technology

ADAMS valves, designed for critical requirements, have proven their reliability and efficiency since 1960 in a wide range of applications throughout the world.

The manufacturing range includes sizes from 80 mm / 3 inches to 3600 mm / 144 inches, operating temperatures from -196°C / -320°F to 950°C / 1742°F, and pressure ratings up to 400bar / 6000 psi.

ADAMS valves are designed to comply with accepted international standards: ANSI, API, ASME, MSS, DIN/EN/ISO, BS, AFNOR, GOST, etc.

A variety of materials allow tailored construction and complete adaptability to meet customers' requirements.





Rotary Tight Shut-Off Valve – MAK

Rotary valve technology, with metal-to-metal torque seating, offers exceptional performance, durability and reliability. Our valves have proven their longevity in the most critical applications, under extreme working conditions and millions of cycles.

When comparing to gate, plug, ball or position seated conventional butterfly valves, you will discover the “low cost of ownership” benefits of the MAK over the life of your system.



Technical Features MAK

- Metal-to-Metal Torque Seating
- Symmetrical Seal Ring in Body
- Triple eccentric Sealing
- Flanged or Butt-Weld Construction
- Body Length to: DIN EN 558 and ISO 5752 Series 13 + 14, ASME B 16.10, API 609
- Inherently Fire-Safe
- Low Fugitive Emissions
- German “TA-Luft”-Specification
- Compact Size / Low Weight
- Save Piping Space
- Reduced Piping Loads
- Reduced Installation Cost
- Stable Control Characteristics
- Replaceable internal parts
- Bi-Directional
- Zero Leakage

Design

Nominal Diameters:

80 mm / 3 inches to 2000 mm / 80 inches

Temperature Range:

Laminated Seal:

-196°C / -320°F to 500°C / 932°F

L2 Seal:

-46°C / -50°F to 600°C / 1112°F

Solid Seal:

-46°C / -50°F to 600°C / 1112°F

Pressure Class:

ASME 150/300/600/(900 on special request)

PN 10/16/25/40/64/100

Actuator Options:

Manual Gear, Pneumatic, Electric, Hydraulic





The ADAMS MAK Sealing System

Due to the **Unique Seat Geometry**, the disc moves without any jamming even at High Temperature Differentials and under Full Rated Pressure.

In the closed position, **torque applied to the shaft is transferred by keyed- or splined-connection to the disc** which is firmly pressed against the seal ring.

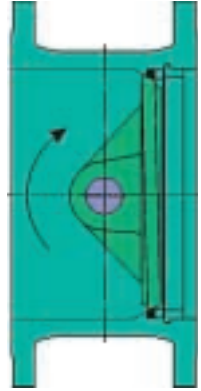

With the **laminated seal ring** held statically in place, **no flexing or movement** occurs. This rugged system produces high sealing loads, **without rubbing**, assuring the most dependable **zero-leakage** shut-off in critical applications.

Utilizing a pure metallic, pressure assisted sealing system, the patented **L2 design** provides **class VI** shut-off, while reducing the operating valve torque.

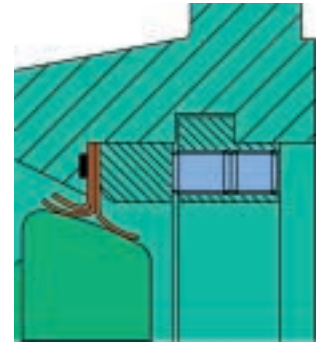

A **solid metal sealing ring** provides positive shut-off capability at **high temperatures** and with **abrasive media**.

With no contact between seal and disc throughout the travel, the valve is now in the full open position. The MAK shaft is supported by **extremely robust and highly engineered bearings** which provide a long trouble-free life. An important aspect of the MAK's rotary motion and packing is the control of **fugitive emissions**.

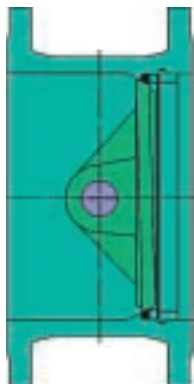
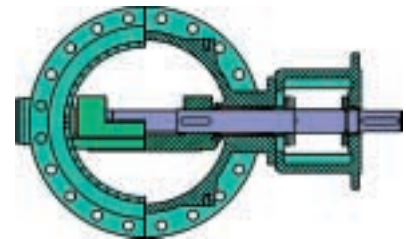

The ultimate advantage of the MAK is its zero leakage, bi-directional shut-off in gases, steam and liquids even when particulates are present. Its metal-to-metal sealing system, and the protected seal in the body, combining patented technology with conservatively engineered design, provides critical **bi-directional** shut-off in the most aggressive and challenging applications.

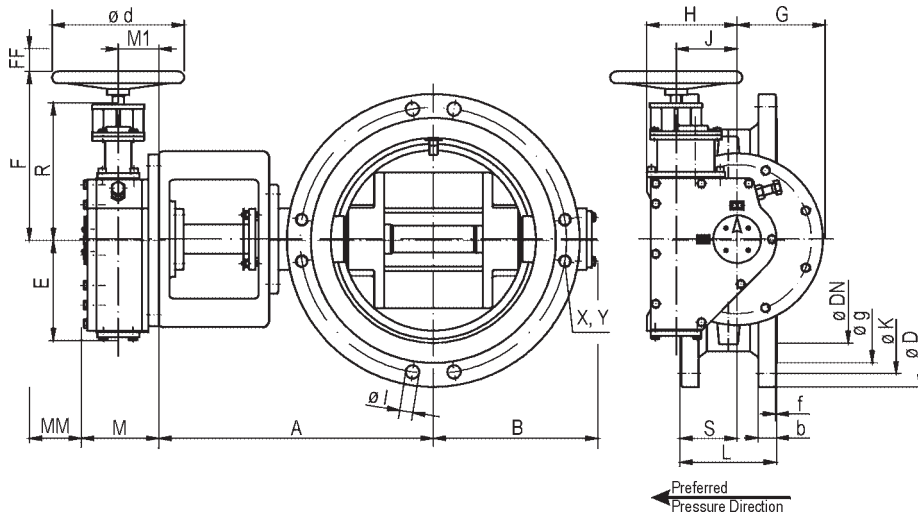

Flange Connection DIN 2501 - PN10

DN in mm/inch, all other dimensions in mm, weight (W) in kg

DN	Q	A	B	M	MM	M1	E	R	F	FF	d	J	G	H	L	S	D	K	g	b	f	n	l	X	Y	nX	W
80/ 3	0	295	131	115	100	51	83	129	199	45	200	83	110	146	114	57	200	160	138	24	3 (2)	8	18	M16	27	8	50
100/ 4	0	306	140	115	100	51	83	129	199	45	200	83	110	146	127	64	220	180	158	20	3 (2)	8	18	M16	25	8	54
150/ 6	0	367	171	115	100	51	83	129	199	45	200	83	110	146	140	81	285	240	212	22	3 (2)	8	22	M20	30	8	82
200/ 8	0	387	195	115	100	51	83	129	199	45	200	83	110	146	152	89.	340	295	268	24	3 (2)	8	22	M20	30	8	98
250/10	1	422	222	134	120	70	95	139	212	45	250	83	145	146	165	95	395	350	320	26	3 (2)	12	22	M20	36	8	125
300/12	2	455	255	169	145	76	116	193	267	45	250	146	175	210	178	104	445	400	370	26	4 (2)	12	22	M20	36	8	176
350/14	2	470	282	169	145	76	116	193	267	45	250	146	175	210	190	104	505	460	430	26	4 (2)	16	22	M20	36	8	195
400/16	4	520	320	163	155	89	175	184	254	45	315	115	172	178	216	126	565	515	482	26	4 (2)	16	26	M24	36	8	277
450/18	4	541	329	163	155	89	175	184	254	45	315	115	172	178	222	135	615	565	532	28	4 (2)	20	26	M24	39	8	321
500/20	4	577	365	163	155	89	175	184	254	45	315	115	172	178	229	135	670	620	585	28	4 (2)	20	26	M24	37	8	370
600/24	5	709	415	185	170	97	238	330	405	55	315	145	205	215	267	146	780	725	685	28 (34)	5 (2)	20	30	-	-	-	524

Optional: Flanges EN 1092-1/21 - PN 10 (see Dim in ())

Flanges DIN 2543 - PN16

DN	Q	A	B	M	MM	M1	E	R	F	FF	d	J	G	H	L	S	D	K	g	b	f	n	l	X	Y	nX	W
80/ 3	0	295	131	115	100	51	83	129	195	45	200	83	110	146	114	57	200	160	138	24	3 (2)	8	18	M16	27	8	50
100/ 4	0	306	140	115	100	51	83	129	195	45	200	83	110	146	127	64	220	180	158	20	3 (2)	8	18	M16	25	8	54
150/ 6	0	366	171	115	100	51	83	129	195	45	200	83	110	146	140	81	285	240	212	22	3 (2)	8	22	M20	30	8	82
200/ 8	1	397	197	134	120	70	95	139	212	45	250	83	145	146	152	89.	340	295	268	24	3 (2)	12	22	M20	30	8	109
250/10	2	430	230	169	145	76	116	193	267	45	250	146	175	210	165	95	405	355	320	26	3 (2)	12	26	M24	36	8	146
300/12	2	455	255	169	145	76	116	193	267	45	250	146	175	210	178	104	460	410	378	28	4 (2)	12	26	M24	36	8	176
350/14	4	498	298	163	155	89	175	184	254	45	315	115	172	178	190	104	520	470	438	30	4 (2)	16	26	M24	37	8	218
400/16	4	520	320	163	155	89	175	184	254	45	315	115	172	178	216	126	580	525	490	32	4 (2)	16	30	M27	40	8	277
450/18	5	629	367	185	170	97	238	329	404	55	315	145	205	215	222	135	640	585	532**	34 (40)	4 (2)	20	30	M27	38	8	385
500/20	5	655	393	185	170	97	238	329	404	55	315	145	205	215	229	135	715	650	610	36 (44)	4 (2)	20	33	M30	46	8	434
600/24	5	715	452	185	170	97	238	329	404	55	315	145	205	215	267	146	840	770	725	40 (54)	5 (2)	20	36	M33	52	8	524

(Optional: Flanges EN 1092-1/21 - PN 16 (see Dim in ()))

** DN450/18 new DIA. g=550

Subject to Modification



MAK - 16

DIN - Flanges

Flange-Facing acc. to DIN 2526, Form C
 Optional: Flange Facing acc. to EN 1092-1, Form B1

- X = Thread Size of Flange Hole
- Y = Depth of Threaded Flange Holes
- nX = Total Number of Threaded Flange Holes
- n = Number of Flange Holes
- l = Diameter of Flange Holes

- L = Face to Face (BL)
- Q = Gear Size (No.)

Larger sizes and special design on request

Material

- Valve Body - GP240GH+N
A216 WCB
- Disc - GP240GH+N ENP
A 216 WCB ENP
- Drive Shaft - X17CrNi16-2+QT800
A 276 TP 431
- Sealing - X6CrNiMoTi17-12-2+AT/Graphite
A 240 TP 316 Ti/Graphite
- Bearing - GGG-NiCr20 2
A 431 TP D2 (Ni-Resist)

Flanges DIN 2544 - PN25

DN in mm/inch, all other dimensions in mm, weight (W) in kg

DN	Q	A	B	M	MM	M1	E	R	F	FF	d	J	G	H	L	S	D	K	g	b	f	n	l	X	Y	nX	W
80/ 3	0	295	131	115	100	51	89	129	195	45	200	82	110	146	180	90	200	160	138	24	3 (2)	8	18	-	-	-	50
100/ 4	0	358	150	115	100	51	89	129	195	45	200	82	110	146	190	95	235	190	162	24	3 (2)	8	22	-	-	-	64
150/ 6	1	388	188	134	120	70	95	139	212	45	250	83	145	146	210	105	300	250	218	28	3 (2)	8	26	-	-	-	100
200/ 8	2	417	217	169	145	76	116	193	267	45	250	146	175	210	230	115	360	310	278	30	3 (2)	12	26	-	-	-	150
250/10	2	438	238	169	145	76	116	193	267	45	250	146	175	210	250	125	425	370	335	32	3 (2)	12	30	-	-	-	182
300/12	4	479	267	163	155	89	175	184	254	45	315	115	172	178	270	135	485	430	395	34	4 (2)	16	30	-	-	-	265
350/14	4	502	306	163	155	89	175	184	254	45	315	115	172	178	290	145	555	490	450	38	4 (2)	16	33	-	-	-	316
400/16	5	622	356	185	170	97	238	329	404	55	315	145	205	215	310	155	620	550	505	40	4 (2)	16	36	-	-	-	462
450/18	5	618	372	185	170	97	238	329	404	55	315	145	205	215	330	165	670	600	555	42 (46)	4 (2)	20	36	-	-	-	54
500/20	5	645	399	185	170	97	238	329	404	55	315	145	205	215	350	175	730	660	615	44 (48)	4 (2)	20	36	-	-	-	615
600/24	6	746	468	220	195	117	300	390	465	55	400	191	265	281	390	195	845	770	720	46 (58)	5 (2)	20	39	-	-	-	946

(Optional: Flanges EN 1092-1/21 - PN 25 (see Dim in ()))

Flanges DIN 2545 - PN40

DN	Q	A	B	M	MM	M1	E	R	F	FF	d	J	G	H	L	S	D	K	g	b	f	n	l	X	Y	nX	W
80/ 3	0	295	131	115	100	51	89	129	195	45	200	82	110	146	180	90	200	160	138	24	3 (2)	8	18	-	-	-	50
100/ 4	0	358	150	115	100	51	89	129	195	45	200	82	110	146	190	95	235	190	162	24	3 (2)	8	22	-	-	-	64
150/ 6	1	388	188	134	120	70	95	139	212	45	250	83	145	146	210	105	300	250	218	28	3 (2)	8	26	-	-	-	100
200/ 8	2	417	217	169	145	76	116	193	267	45	250	146	175	210	230	115	375	320	285	34	3 (2)	12	30	M27	49	8	168
250/10	4	464	252	163	155	89	175	184	254	45	315	115	172	178	250	125	450	385	345	38	3 (2)	12	33	M30	45	8	257
300/12	5	547	289	185	170	97	238	329	404	55	315	145	205	215	270	135	515	450	410	42	4 (2)	16	33	M30	51	8	389
350/14	5	580	318	185	170	97	238	329	404	55	315	145	205	215	290	145	580	510	465	46	4 (2)	16	36	M33	57	8	446
400/16	5	622	356	185	170	97	238	329	404	55	315	145	205	215	310	155	660	585	535	50	4 (2)	16	39	M36	63	8	551
450/18	6	673	395	220	195	117	300	390	465	55	400	191	265	281	330	165	685	610	560	50 (57)	4 (2)	20	39	M36	63	8	743
500/20	6	700	422	220	195	117	300	390	465	55	400	191	265	281	350	175	755	670	615	52 (57)	4 (2)	20	42	M39	71	8	830
600/24	7	775	495	255	210	124	400	485	560	55	400	270	267	380	390	195	890	795	735	60 (72)	5 (2)	20	48	M45	73	8	1299

(Optional: Flanges EN 1092-1/21 - PN 40 (see Dim in ()))

Subject to Modification



MAK - B6

ASME - Flanges

Flange-Facing acc. to ASME B16.5, Form RF

- X = Thread Size of Flange Hole
X < 1" UNC 2B; X > 1" UN 2B
- Y = Depth of Threaded Flange Holes
- nX = Total Number of Threaded Flange Holes
- n = Number of Flange Holes
- l = Diameter of Flange Holes
- L = Face to Face (BL)
- Q = Gear Size (No.)

Larger sizes and special design on request

Material

- Valve Body - GP240GH+N
A216 WCB
- Disc (16) - GP240GH+N ENP
A 216 WCB ENP
(B6) - X5CrNiMo17-12-2+AT
A 182 F 316
- Drive Shaft - X17CrNi16-2+QT800
A 276 TP 431
- Sealing - X6CrNiMoTi17-12-2+AT/Graphite
A 240 TP 316 Ti/Graphite
- Bearing - GGG-NiCr20 2
A 431 TP D2 (Ni-Resist)

Flanges ASME B 16.5 - Class 150

DN in mm/inch, X in inch, all other dimensions in mm, weight (W) in kg

DN	Q	A	B	M	MM	M1	E	R	F	FF	d	J	G	H	L	S	D	K	g	b	f	n	l	X	Y	nX	W
80/3	0	260	122	115	50	51	96	124	193	60	200	82	110	146	114	32	190,5	152,4	127,0	23,9	1,6	4	19,1	-	-	-	40
100/4	0	261	128	115	50	51	96	124	193	60	200	82	110	146	127	32	228,6	190,5	157,2	23,9	1,6	8	19,1	5/8-11	30	4	46
150/6	0	292	154	115	50	51	96	124	193	60	200	82	110	146	140	46	279,4	241,3	215,9	25,4	1,6	8	22,4	3/4-10	30	4	56
200/8	1	330	187	115	55	51	89	124	194	60	250	82	110	146	152	45	342,9	298,5	269,7	28,4	1,6	8	22,4	3/4-10	30	4	75
250/10	1	361	227	115	55	51	89	124	194	60	250	82	110	146	165	57	406,4	362,0	323,9	30,2	1,6	12	25,4	7/8-9	30	4	98
300/12	2	403	258	168	85	77	153	191	264	60	250	145	175	210	178	57	482,6	431,8	381,0	31,8	1,6	12	25,4	7/8-9	30	4	168
350/14	4	442	294	163	105	89	173	182	252	60	315	115	165	178	190	64	533,4	476,3	412,8	35,1	1,6	12	28,5	1-8	30	4	225
400/16	4	468	320	163	105	89	173	182	252	60	315	115	165	178	216	70	596,9	539,8	469,9	36,6	1,6	16	28,5	1-8	30	4	261
450/18	5	498	356	190	135	102	235	328	403	60	315	145	198	215	222	81	635,0	577,9	533,4	39,6	1,6	16	31,8	1 1/8-8	46	8	359
500/20	5	518	376	190	135	102	235	328	403	60	315	145	198	215	229	88	698,5	635,0	584,2	42,9	1,6	20	31,8	1 1/8-8	40	8	408
600/24	6	598	444	236	155	133	296	389	464	60	400	191	230	281	267	89	812,8	749,3	692,2	47,8	1,6	20	35,1	1 1/4-8	42	4	629

Flanges ASME B16.5 - Class 300

DN	Q	A	B	M	MM	M1	E	R	F	FF	d	J	G	H	L	S	D	K	g	b	f	n	l	X	Y	nX	W
80/3	0	260	127	115	50	51	96	124	193	45	200	82	110	146	114	32	209,6	168,1	127,0	28,4	1,6	8	22,4	3/4-10	32	8	44
100/4	1	276	134	115	55	51	89	124	198	45	250	82	110	146	127	40	254,0	200,2	157,2	31,8	1,6	8	22,4	3/4-10	36	8	58
150/6	1	330	184	115	55	51	89	124	198	45	250	82	110	146	140	53	317,5	269,7	215,9	36,6	1,6	12	22,4	3/4-10	30	8	82
200/8	2	363	207	168	85	77	153	191	264	45	250	145	175	210	152	60	381,0	330,2	269,7	41,1	1,6	12	25,4	7/8-9	30	8	142
250/10	4	416	244	163	105	89	173	182	252	60	315	115	165	178	165	75	444,5	387,4	323,9	47,8	1,6	16	28,5	1-8	30	8	205
300/12	5	447	281	190	135	102	235	328	403	60	315	145	198	215	178	85	520,7	450,9	381,0	50,8	1,6	16	31,8	1 1/8-8	35	8	318
350/14	5	471	317	190	135	102	235	328	403	60	315	145	198	215	190	95	584,2	514,4	412,8	53,8	1,6	20	31,8	1 1/8-8	35	8	379
400/16	6	496	342	236	155	133	296	389	464	60	400	191	230	281	216	105	647,7	571,5	469,9	57,2	1,6	20	35,1	1 1/4-8	40	8	537
450/18	6	540	376	236	175	133	296	389	464	60	400	191	230	281	222	115	711,2	628,7	533,4	60,5	1,6	24	35,1	1 1/4-8	38	16	628
500/20	7	566	421	269	195	138	396	484	559	60	400	270	260	380	229	125	774,7	685,8	584,2	63,5	1,6	24	35,1	1 1/4-8	31	8	869
600/24	7	626	478	269	210	138	396	484	559	60	400	270	260	380	267	145	914,4	812,8	692,2	69,9	1,6	24	41,1	1 1/2-8	44	8	1133

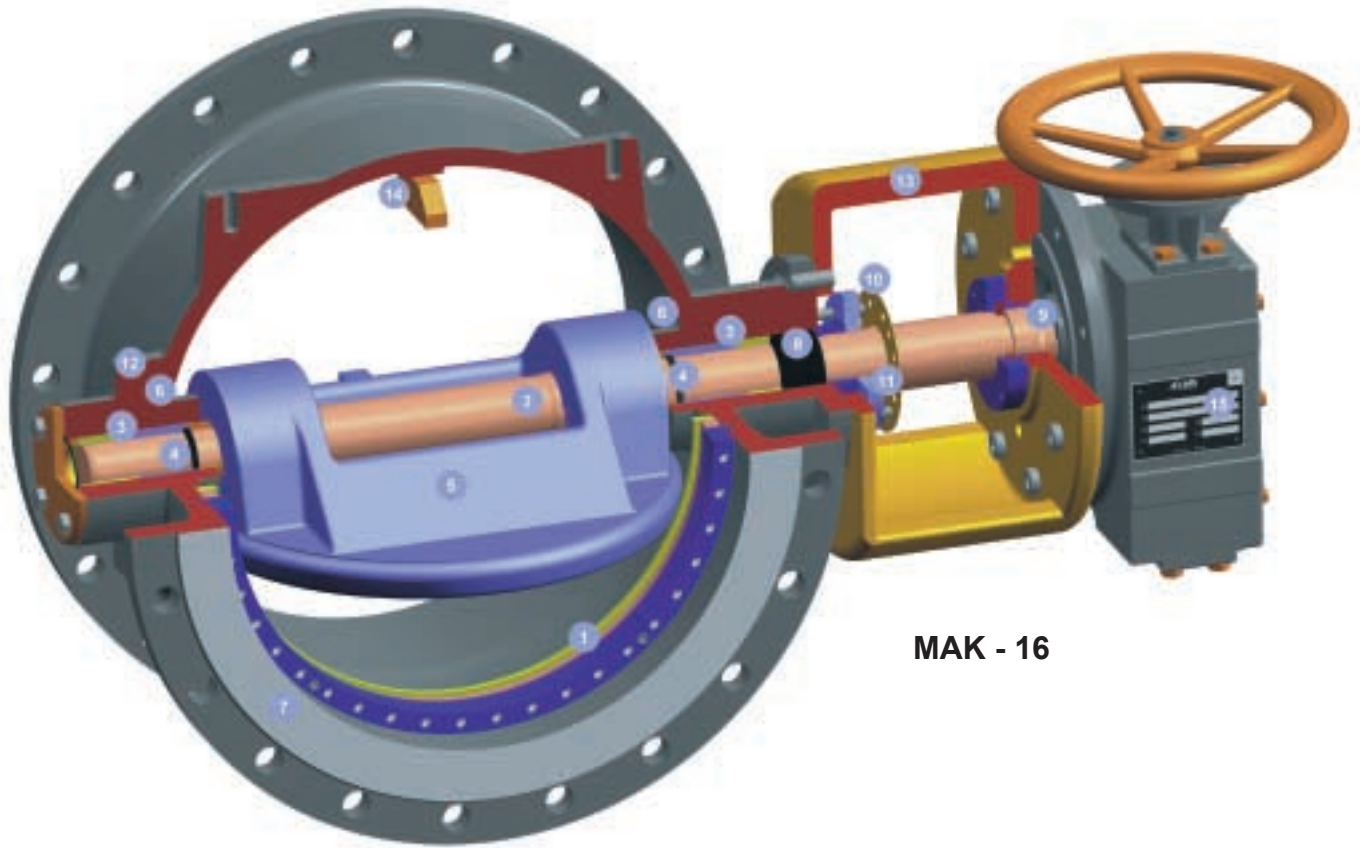

MAK - 16

1. Unique field-replaceable seal system in body
2. Keyed or splined disc-to-shaft connection
3. Robust top and bottom shaft bearings
4. Energized bearing protectors
5. Rigid disc design minimizes deflection
6. Extended body hubs
7. Full face flanges
8. Emission tight packing system
9. External blowout prevention and bearing system
10. External valve position indication
11. Self-centering packing gland (four studs minimum)
12. Integrally cast purge / grease port bosses
13. Heavy duty cast operator mounting bracket rigidly pinned and registered to body
14. Disc over-travel stop (safety feature)
15. Manual operators specifically engineered

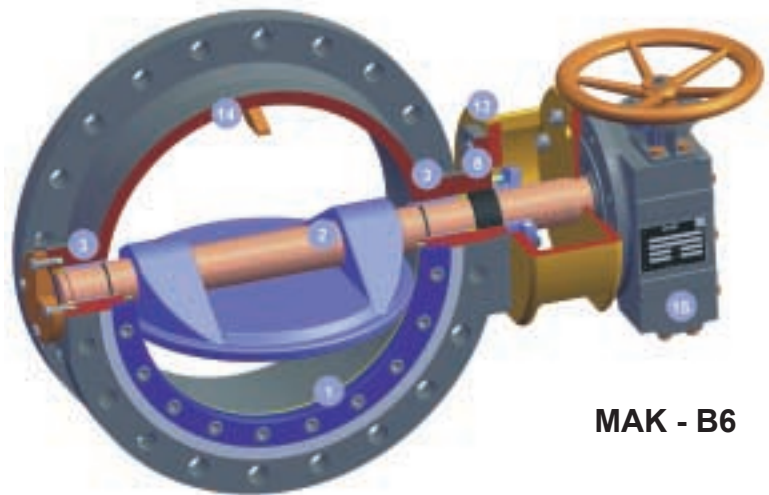

MAK - B6

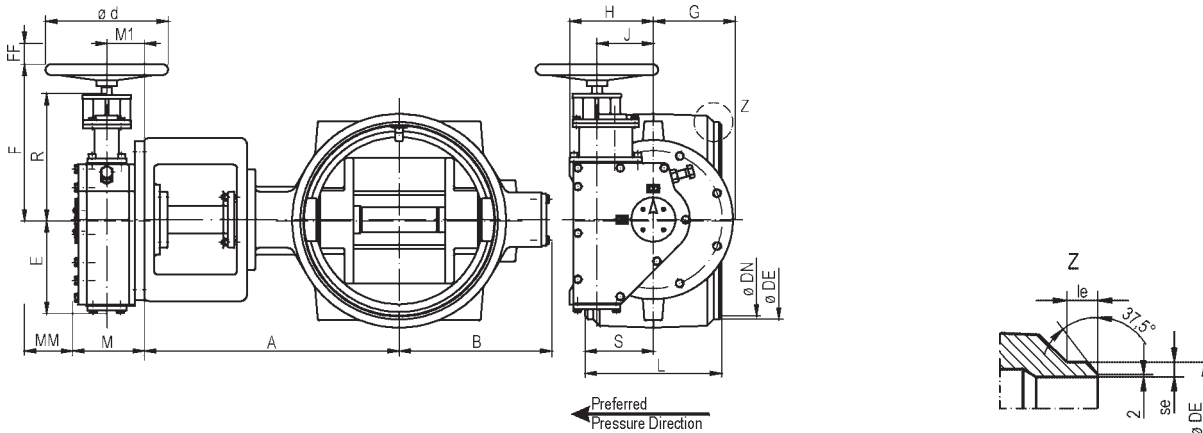

PN 16 DN in mm/inch, all other dimensions in mm, weight (W) in kg

DN	Q	A	B	M	MM	M1	E	R	F	FF	d	J	G	H	L	S	DE	se	le	W
80/ 3	0	295	131	115	100	51	83	129	195	45	200	83	110	146	180	90	88,9	3,2	20	45
100/ 4	0	306	140	115	100	51	83	129	195	45	200	83	110	146	190	95	114,3	3,6	20	50
150/ 6	0	366	171	115	100	51	83	129	195	45	200	83	110	146	210	105	168,3	4,5	20	69
200/ 8	1	397	197	134	120	70	95	139	212	45	250	83	145	146	230	115	219,1	5,9	20	93
250/10	2	430	230	169	145	76	116	193	267	45	250	146	175	210	250	125	273,0	6,3	20	138
300/12	2	455	255	169	145	76	116	193	267	45	250	146	175	210	270	135	323,9	7,1	20	159
350/14	4	498	298	163	155	89	175	184	254	45	315	115	172	178	290	145	355,6	8,0	20	220
400/16	4	520	320	163	155	89	175	184	254	45	315	115	172	178	310	155	406,4	8,0	20	255
450/18	5	629	367	185	170	97	238	329	404	55	315	145	205	215	330	165	457,0	8,0	20	404
500/20	5	655	393	185	170	97	238	329	404	55	315	145	205	215	350	175	508,0	8,0	20	447
600/24	5	715	452	185	170	97	238	329	404	55	315	145	205	215	390	195	610,0	8,8	20	577

PN 25 DN in mm/inch, all other dimensions in mm, weight (W) in kg

DN	Q	A	B	M	MM	M1	E	R	F	FF	d	J	G	H	L	S	DE	se	le	W
80/ 3	0	295	131	115	100	51	89	129	195	45	200	82	110	146	180	90	88,9	3,2	10	47
100/ 4	0	358	150	115	100	51	89	129	195	45	200	82	110	146	190	95	114,3	3,6	10	62
150/ 6	1	388	188	134	120	70	95	139	212	45	250	83	145	146	210	105	168,3	4,5	14	85
200/ 8	2	417	217	169	145	76	116	193	267	45	250	146	175	210	230	115	219,1	6,3	12	126
250/10	2	438	238	169	145	76	116	193	267	45	250	146	175	210	250	125	273,0	7,1	14	149
300/12	4	479	267	163	155	89	175	184	254	45	315	115	172	178	270	135	323,9	8,0	15	219
350/14	4	502	306	163	155	89	175	184	254	45	315	115	172	178	290	145	355,6	8,0	20	248
400/16	5	622	356	185	170	97	238	329	404	55	315	145	205	215	310	155	406,4	8,8	20	378
450/18	5	618	372	185	170	97	238	329	404	55	315	145	205	215	330	165	457,0	10,0	20	447
500/20	5	645	399	185	170	97	238	329	404	55	315	145	205	215	350	175	508,0	10,0	24	501
600/24	6	746	468	220	195	117	300	390	465	55	400	191	265	281	390	195	610,0	11,0	22	803

PN 40 DN in mm/inch, all other dimensions in mm, weight (W) in kg

DN	Q	A	B	M	MM	M1	E	R	F	FF	d	J	G	H	L	S	DE	se	le	W
80/ 3	0	295	131	115	100	51	89	129	195	45	200	82	110	146	180	90	88,9	3,2	10	47
100/ 4	0	358	150	115	100	51	89	129	195	45	200	82	110	146	190	95	114,3	3,6	10	62
150/ 6	1	388	188	134	120	70	95	139	212	45	250	83	145	146	210	105	168,3	4,5	14	95
200/ 8	2	417	217	169	145	76	116	193	267	45	250	146	175	210	230	115	219,1	6,3	12	126
250/10	4	464	252	163	155	89	175	184	254	45	315	115	172	178	250	125	273,0	7,1	14	194
300/12	5	547	289	185	170	97	238	329	404	55	315	145	205	215	270	135	323,9	8,0	15	309
350/14	5	580	318	185	170	97	238	329	404	55	315	145	205	215	290	145	355,6	8,8	20	333
400/16	5	622	356	185	170	97	238	329	404	55	315	145	205	215	310	155	406,4	11,0	20	378
450/18	6	673	395	220	195	117	300	390	465	55	400	191	265	281	330	165	457,0	12,5	20	585
500/20	6	700	422	220	195	117	300	390	465	55	400	191	265	281	350	175	508,0	14,2	24	639
600/24	7	775	495	255	210	124	400	485	560	55	400	270	267	380	390	195	610,0	15,9	22	1010

Sch = max. Schedule
 L = Face to Face (BL)
 Q = Gear Size (No.)

Larger sizes and special design on request

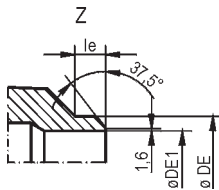

Material

- Valve Body - GP240GH+N
A216 WCB
- Disc - GP240GH+N ENP
A 216 WCB ENP
- Drive Shaft - X17CrNi16-2+QT800
A 276 TP 431
- Sealing - X6CrNiMoTi17-12-2+AT/Graphite
A 240 TP 316 Ti/Graphite
- Bearing - GGG-NiCr20 2
A 431 TP D2 (Ni-Resist)

Class 150

DN in mm/inch, all other dimensions in mm, weight (W) in kg

DN	Q	A	B	M	MM	M1	E	R	F	FF	d	J	G	H	L	S	DE	DE1	Sch	le	W
80/3	0	295	135	115	100	51	83	129	199	45	200	83	110	146	180	90	91,0	78,0	40	15	46
100/4	0	306	155	115	100	51	83	129	199	45	200	83	110	146	190	95	117,0	102,0	40	15	64
150/6	0	367	171	115	100	51	83	129	199	45	200	83	110	146	210	105	172,0	154,0	40	15	70
200/8	1	397	197	134	120	70	95	139	212	45	250	83	145	146	230	115	223,0	203,0	40	15	94
250/10	2	430	230	168	145	76	116	193	267	45	250	146	175	210	250	125	278,0	254,5	40	15	139
300/12	4	483	271	163	155	89	175	184	254	45	315	115	172	178	270	135	329,0	303,0	40	15	198
350/14	4	498	298	163	155	89	175	184	254	45	315	115	172	178	290	145	362,0	336,5	30	20	221
400/16	5	580	334	185	170	97	238	329	404	55	315	145	205	215	310	155	413,0	387,5	30	20	333
450/18	5	629	367	185	170	97	238	329	404	55	315	145	205	215	330	165	464,0	434,5	30	25	407
500/20	5	655	393	185	170	97	238	329	404	55	315	145	205	215	350	175	516,0	489,0	20	25	450
600/24	6	745	452	220	195	117	300	389	464	55	400	191	265	281	390	195	619,0	591,0	20	26	676

Class 300

DN	Q	A	B	M	MM	M1	E	R	F	FF	d	J	G	H	L	S	DE	DE1	Sch	le	W
80/3	0	295	131	115	100	51	83	129	199	45	200	83	110	146	180	90	91,0	78,0	40	15	47
100/4	0	358	150	115	100	51	83	129	199	45	200	83	110	146	190	95	117,0	102,0	40	15	64
150/6	2	388	188	168	145	76	116	193	267	45	250	146	175	210	210	105	172,0	154,0	40	15	106
200/8	4	417	221	163	155	89	175	184	254	45	315	115	172	178	230	115	223,0	203,0	40	15	159
250/10	4	464	252	163	155	89	175	184	254	45	315	115	172	178	250	125	278,0	254,5	40	15	191
300/12	5	547	289	185	170	97	238	329	404	55	315	145	205	215	270	135	329,0	303,0	40	15	307
350/14	5	580	318	185	170	97	238	329	404	55	315	145	205	215	290	145	362,0	333,5	40	20	331
400/16	6	642	369	220	195	117	300	389	464	55	400	191	267	281	310	155	413,0	381,0	40	20	485
450/18	6	673	395	220	195	117	300	389	464	55	400	191	267	281	330	165	464,0	428,5	40	25	585
500/20	6	700	422	220	195	117	300	389	464	55	400	191	267	281	350	175	516,0	478,0	40	25	639
600/24	7	775	495	255	210	124	400	485	560	55	400	270	267	380	390	195	619,0	574,5	40	26	1010

Subject to Modification

Optional Configurations MAK - 16

The following options are available for applications requiring modification from our “standard design”. Please consult factory for further information.

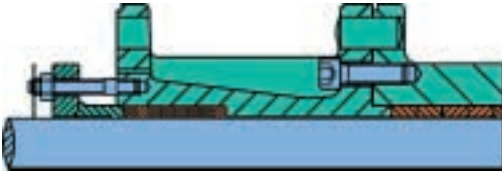

Cryogenic Extension

- Liquefied Natural Gas Plants
- Air Separation
- to -196°C / -320°F

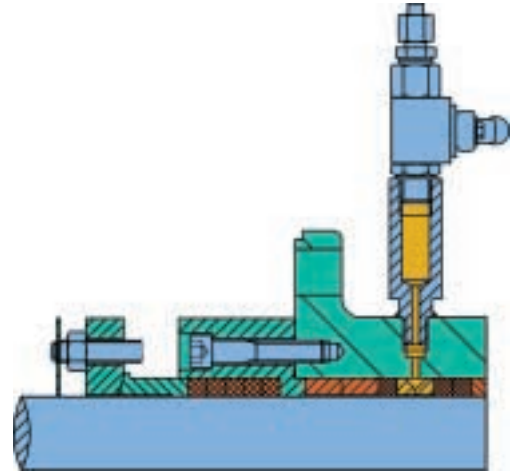

Safety Packing

- Change Primary Packing with Valve in Service

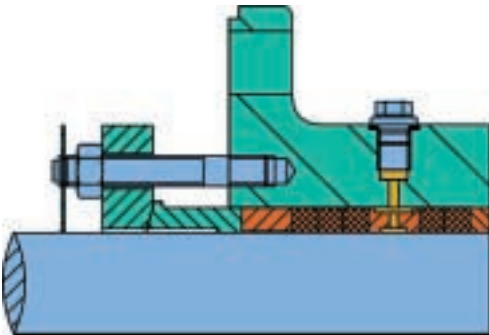

Lantern Ring and Purge Systems

- For Special Shaft Sealing Applications

Additional Options

- Body Jacketing (Heating / Cooling)
- Special Cleaning Options
- Disc Edge Protection
- NACE Design
- Hard-Facing of Disc or Shaft
- High Temperature Extensions
- Out-Board Bearings
- Shaft Steam Tracing
- Top Entry / Access Port for In-Line Maintenance

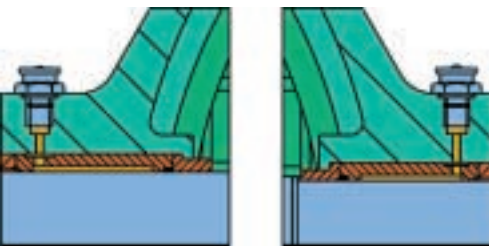

Lubricated Bearings

- Media with High Particulate Content
- Ultra-High Cycle Applications

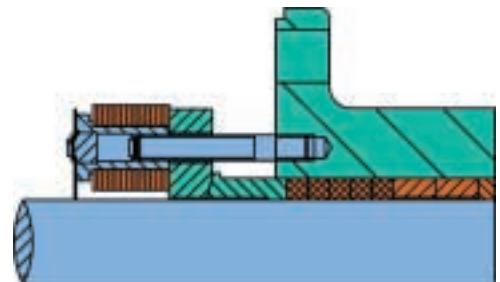

Live Loaded Packing

- Extended Maintenance Cycle



Applications in:

- District Heating
- Steam Distribution
- Refining and Petrochemical
- Power Generation
- Chemical
- Liquefied Natural Gas
- Steel Making
- Pulp and Paper
- Water Works

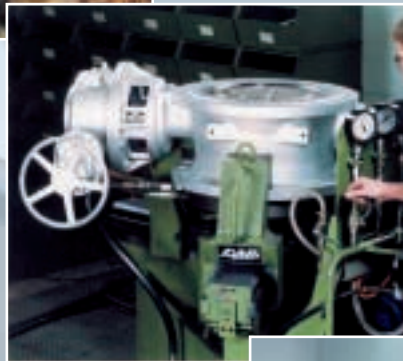

Uncompromising Quality

Our highly qualified staff and facilities guarantee ADAMS' consistent high production standards. An expert team of experienced mobile service personnel is available for on-site staff training and servicing during regular plant maintenance.

During the complete manufacturing process all valves and their components are subjected to stringent quality surveillance. A continuous improvement program includes quality planning, quality control, monitoring, intensive personnel training, regular internal audits, and external suppliers' audits.

Ongoing optimization ensures that all products meet the highest standards.

The ADAMS' quality assurance system also meets the extended requirements of German KTA-rule 1401 as well as other nuclear requirements.



ADAMS Armaturen GmbH

Baukauer Strasse 55
D-44653 Herne
Phone +49 - (0) - 2323 2090
Fax +49 - (0) - 2323 209286
Internet: www.adams-armaturen.de
E-Mail: info@adams-armaturen.de

ADAMS Schweiz AG

Badstrasse 11
CH-7249 Klosters-Serneus
Phone +41 - (0) - 81 4102222
Fax +41 - (0) - 81 4102229
Internet: www.adamsarmaturen.ch
E-Mail: info@adamsarmaturen.ch

ADAMS Valves Inc.

10649 Haddington Dr. No. 160
Houston, Texas 77043 U.S.A.
Phone +1 - (713) - 973-2490
Fax +1 - (713) - 973-2788
Internet: www.adamsvalves-usa.com
E-Mail: info@adamsvalves-usa.com



Since 1960, ADAMS' valves have been internationally proven acclaimed in all major industries and services.

The ADAMS name is synonymous with uncompromising quality.

Today, the ADAMS group has manufacturing facilities in Germany, Switzerland and the United States and multiple sales offices with authorized agents on every continent.

This widespread network assures optimum service to all customers.

To find your local sales agent please log onto one of our websites or contact one of the offices above.